

Behind the Automotive Design Curtain

And The Lessons In Leadership I Had To Learn The Hard Way



Jim Jensen
Director, Design Operations
Canoo





Jim Jensen

Director, Design Operations
Canoo

Over the past 20 years, I have taken my passion for cars and made a career in the automotive field. Starting as a fabricator and technician in the race shop at an aftermarket company, then moving into the Design studios at several major automakers, I jumped into the EV start-up world.

Throughout my career, I have had many different titles that, include Fabricator, Hard Modeler, CNC Programmer, Fabrication Engineer, Project Manager, Program Manager, and now Director of Design Operations.

Having experiences in so many different aspects of the industry has given me a unique perspective on the various aspects that intertwine in a design studio and how to lead the various parts of a design team.



Agenda

- Automotive Design
 - Involved Groups
 - Process & Technologies
- Getting Ahead & Leadership
 - Personal Expectations
 - Leading Small Teams
 - Leading Entire Departments

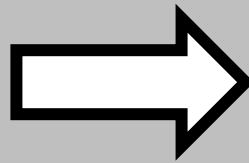
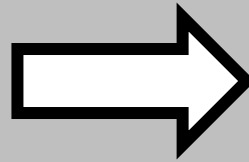

Sub Departments within Automotive Design Studios

Vehicle Design

- Interior Design
- Exterior Design
- Color, Materials, and Finishes
- Studio Engineering
- Concept CAD Modeling
- Clay Modeling
- Fabrication
- A-Class Modeling
- Design Quality

Non-Vehicle Design

- Web Design
- Branding
- Experiential Design
- Video Design
- Merchandise Design
- UI/UX Design
- Project Management

Sub Departments within Automotive Design Studios

Vehicle Design

- Interior Design
- Exterior Design
- Color, Materials, and Finishes
- Studio Engineering
- Concept CAD Modeling
- Clay Modeling
- Fabrication
- A-Class Modeling
- Design Quality

Non-Vehicle Design

- Web Design
- Branding
- Experiential Design
- Video Design
- Merchandise Design
- UI/UX Design
- Project Management

Digital Process Flow

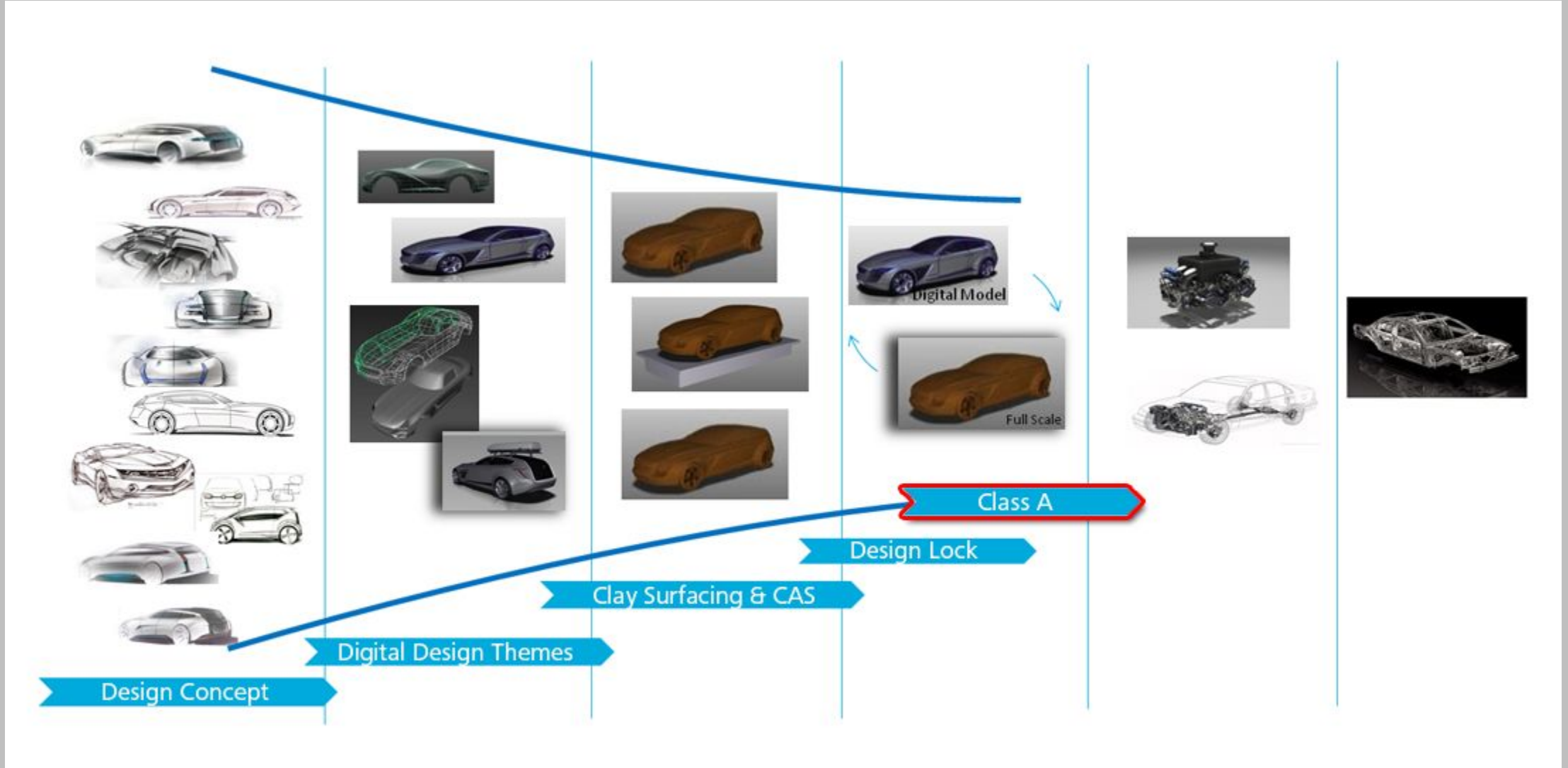

Design Department Activity Timing

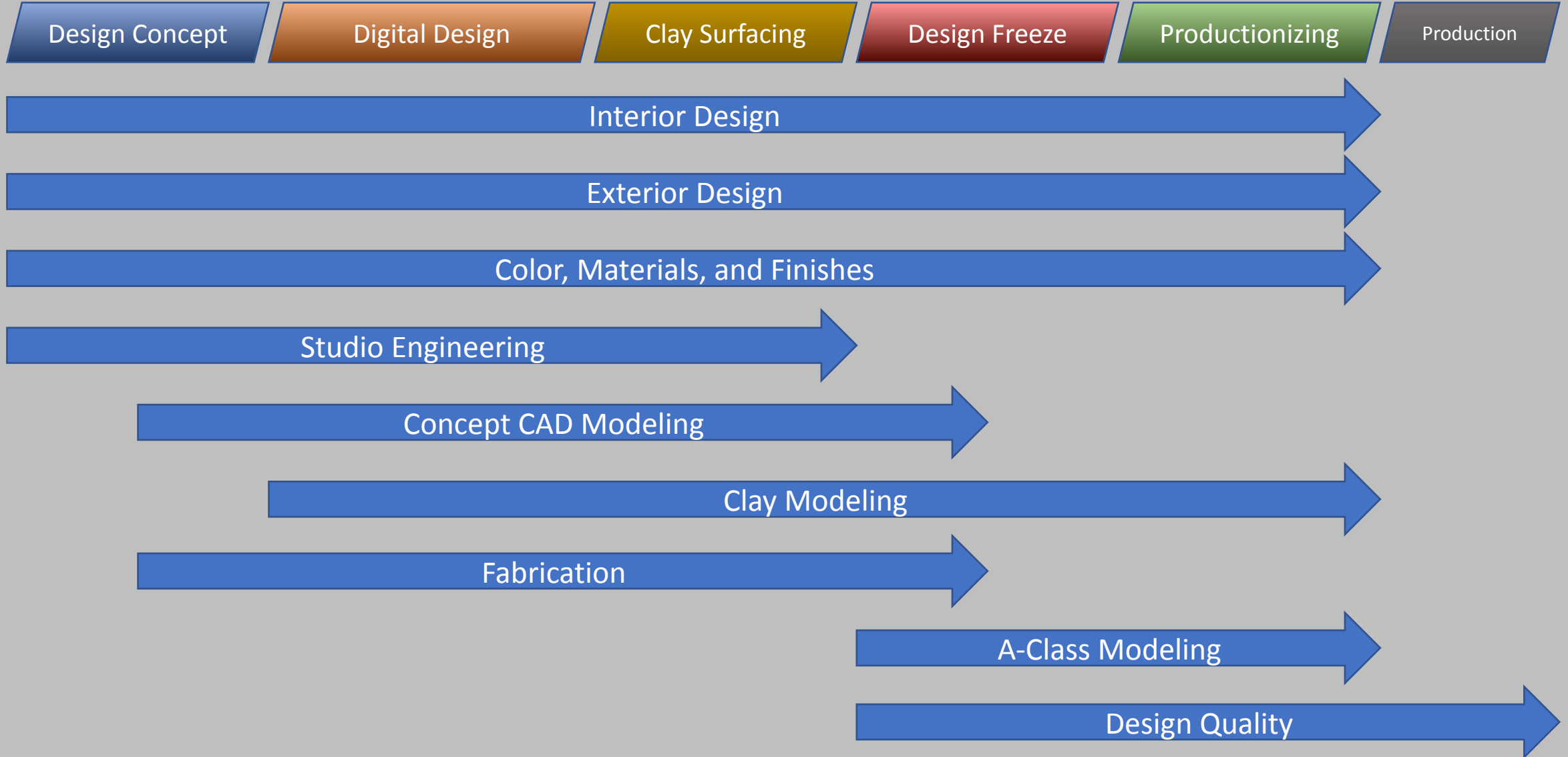

Exterior Design- Design Sketching

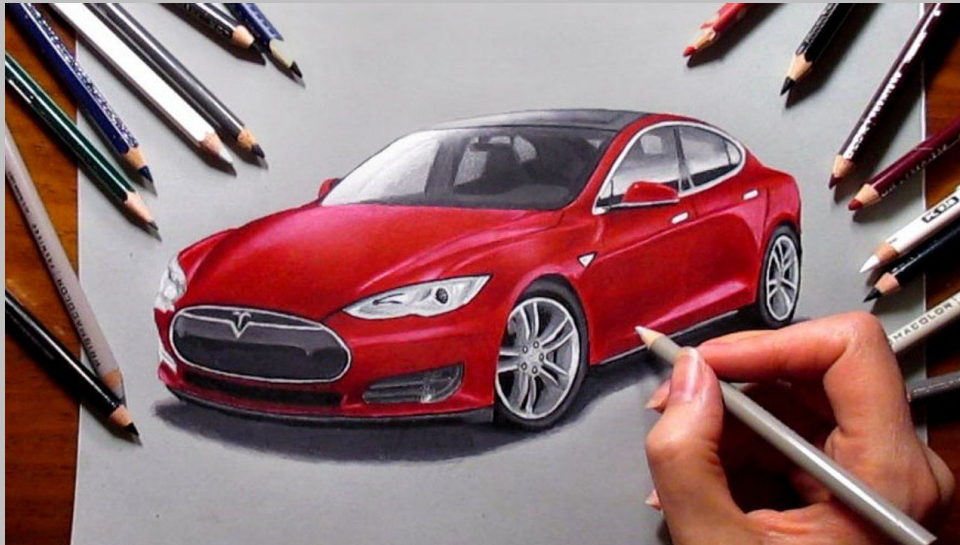
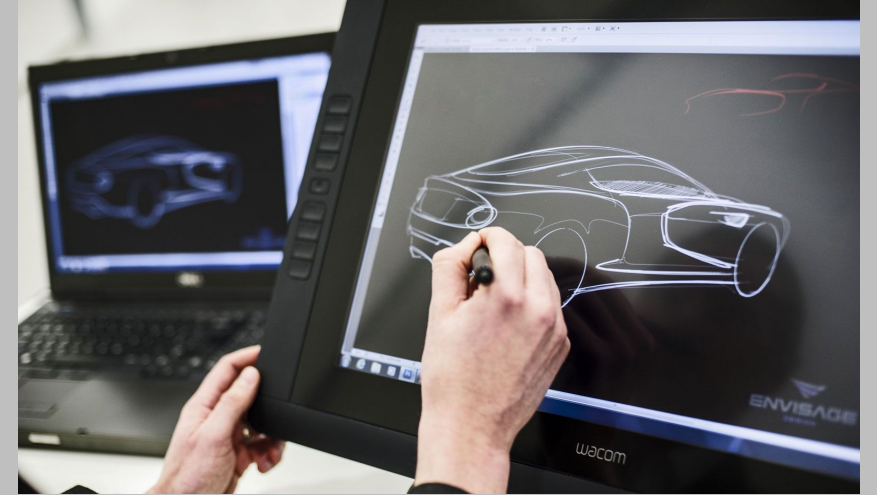

Interior Design- Design Sketching



Color, Materials & Finish (CMF) Design

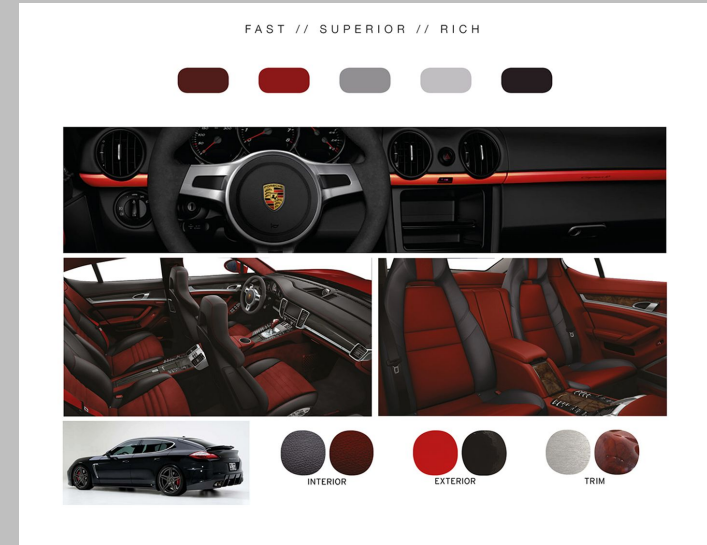
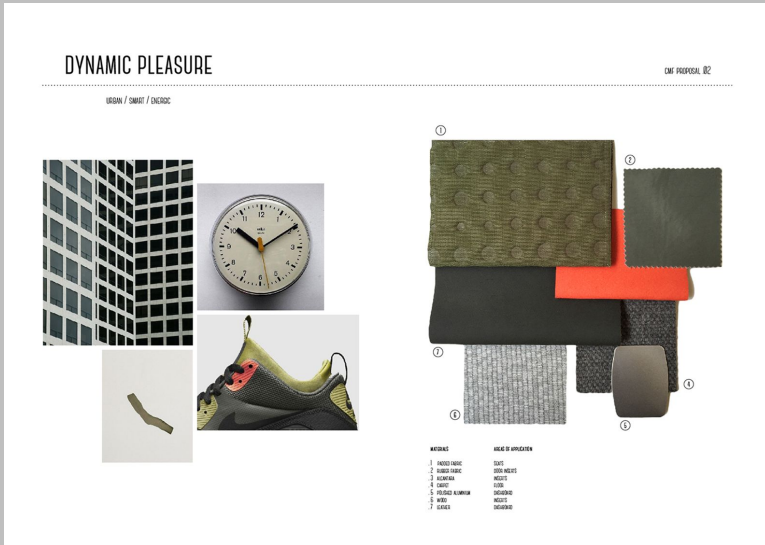

Studio Engineering

KEY DIMENSIONS

These key dimensions are used to set up and communicate the size and attributes of the package. Developing concepts are under continuous scrutiny and these measurements help to keep the design team informed. Additional dimensions may need to be added depending on the type of vehicle and its functional objectives. An off-road truck, for example, may need to record ground clearance and bed length.

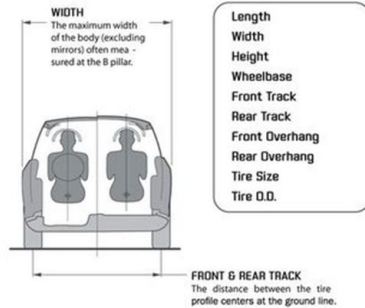

TIRE SIZE & TIRE OUTSIDE DIAMETER (O.D.)
Tires are specified by their profile width, height and the wheel diameter. These dimensions are also combined to produce the tire outside diameter.



00 | H-POINT

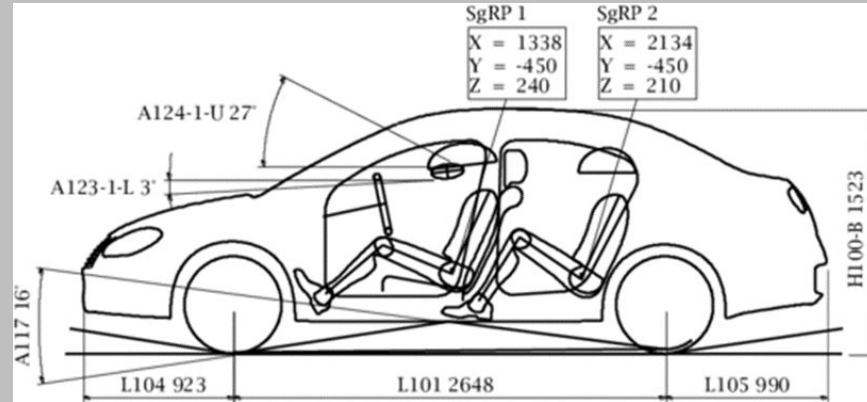

GCIE definition

SgRP 1	...Seating reference point driver
SgRP 2	...Seating reference point passenger
A124-1-U	...Vision - forward up of driver
A123-1-L	...Vision - forward down of Y-plane
A117	...Ramp angle at maximum load
L104	...Overhang front
L101	...Wheelbase
L105	...Overhang rear
H100-B	...Vehicle height - body

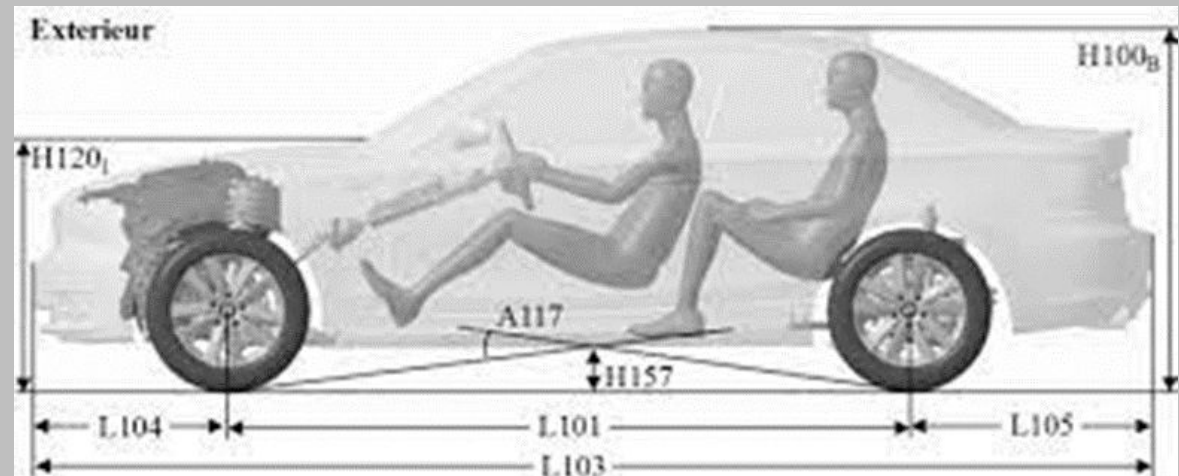

3DEXPERIENCE®

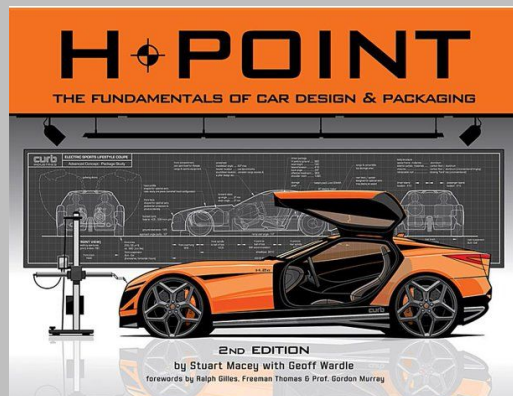

Studio Engineering – Physical Packaging Studies



Concept CAD Modeling

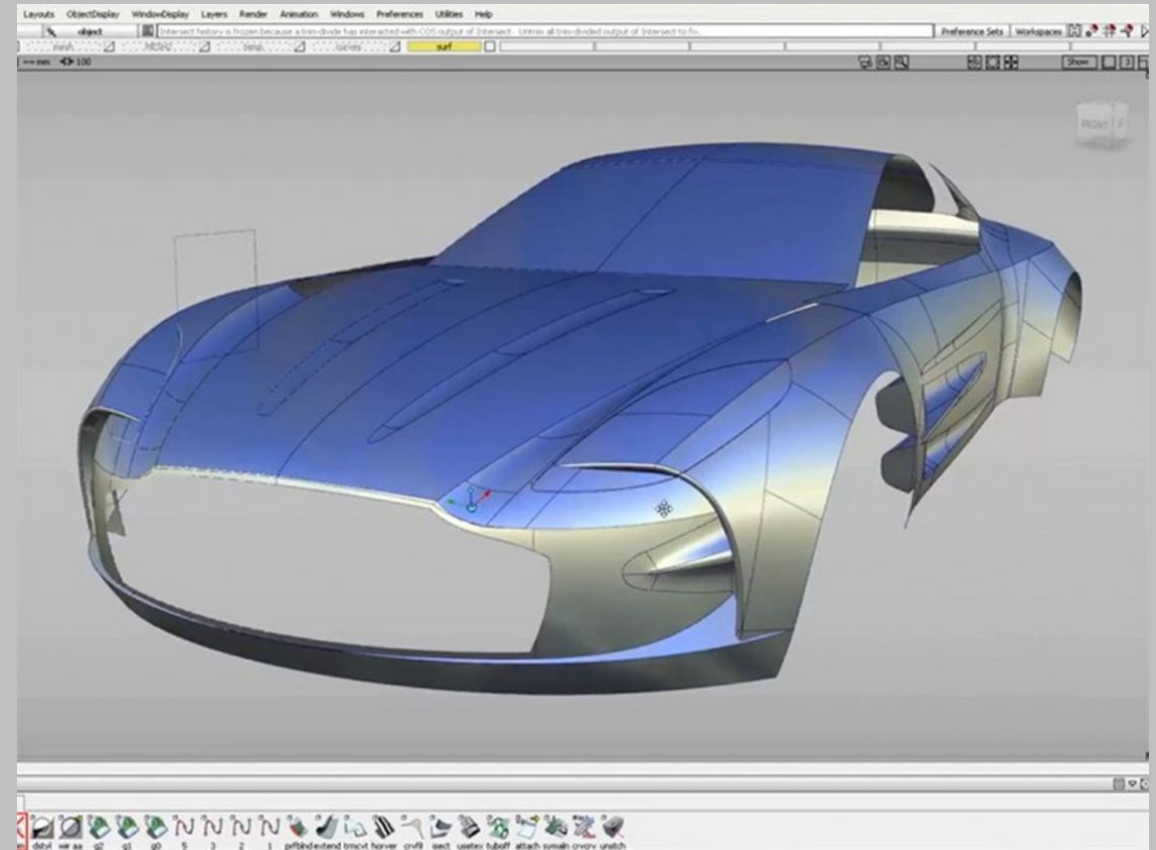
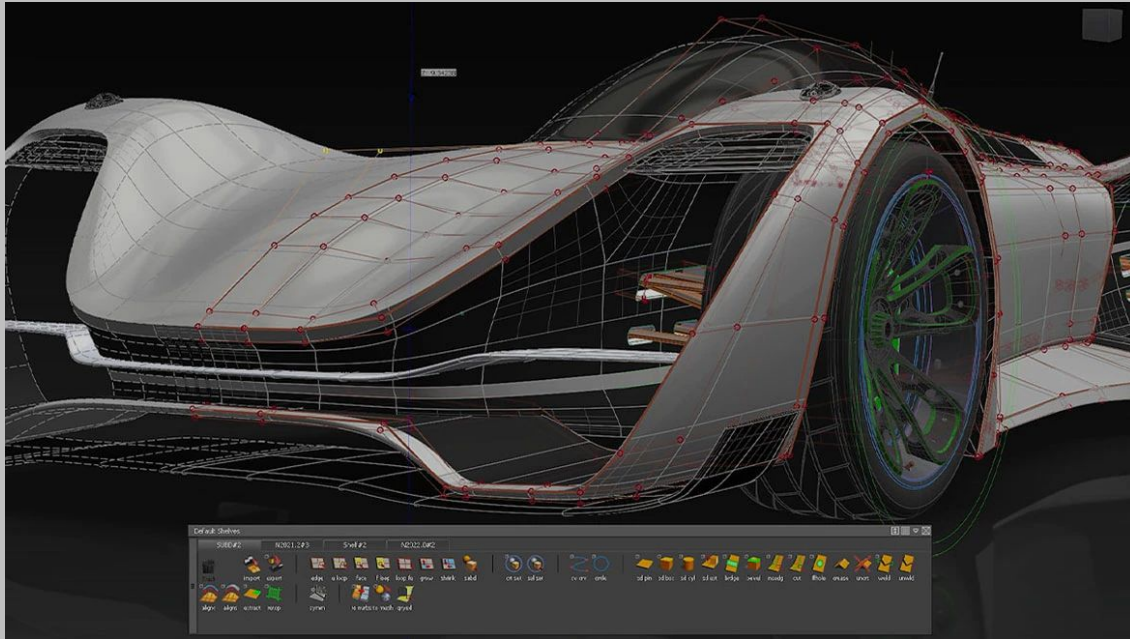

AUTODESK Alias

Virtual Reality Design Verification



Clay Modeling

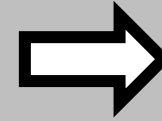
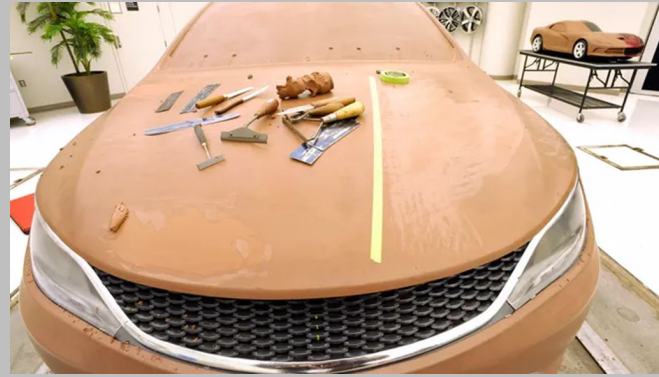
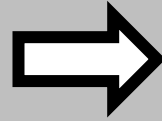

3D Scanning

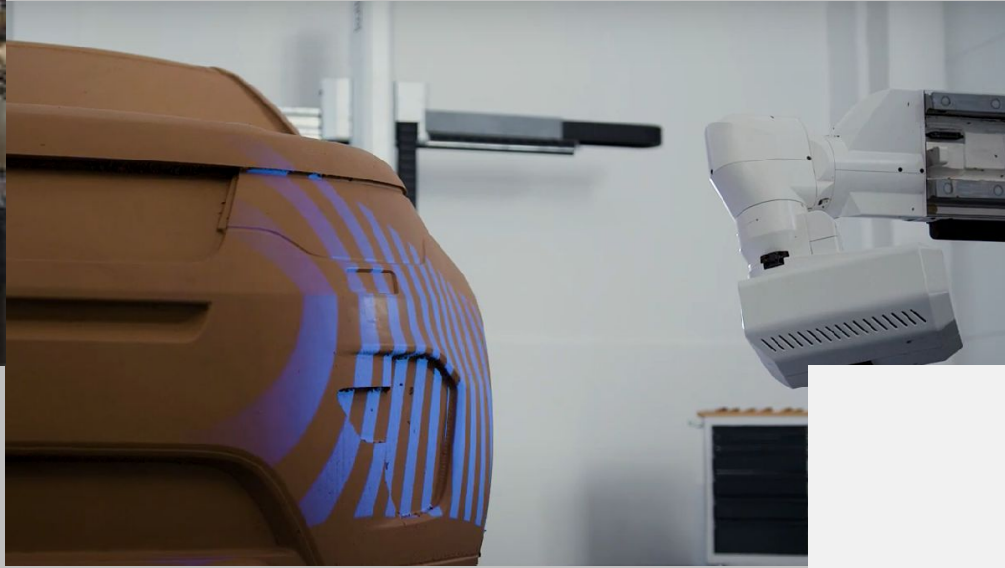

Design Studio Fabrication

- Metal Fabrication
- Wood Fabrication
- Composites
- Hard Modeling
- CNC Machining
- 3D Printing
- Painting
- Surfacing
- Thermoforming
- Upholstery

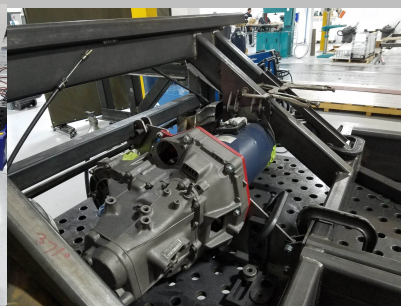
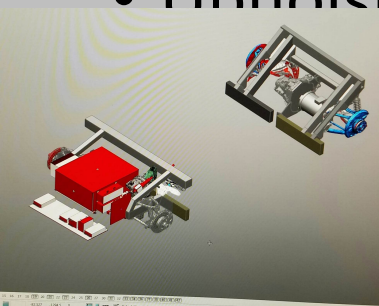
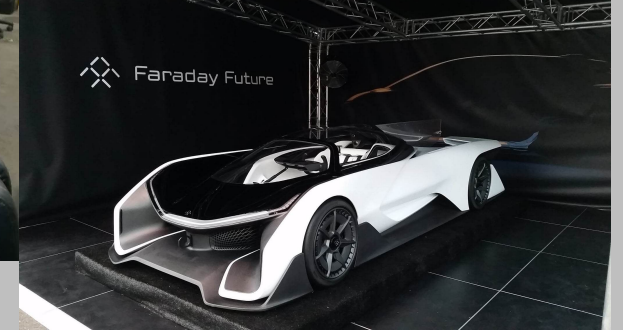

A-Class Modeling

- Every single component and surface that is customer facing
- Creates perfect gaps
- Adjusts for tooling draft angles
- Creates every minute detail

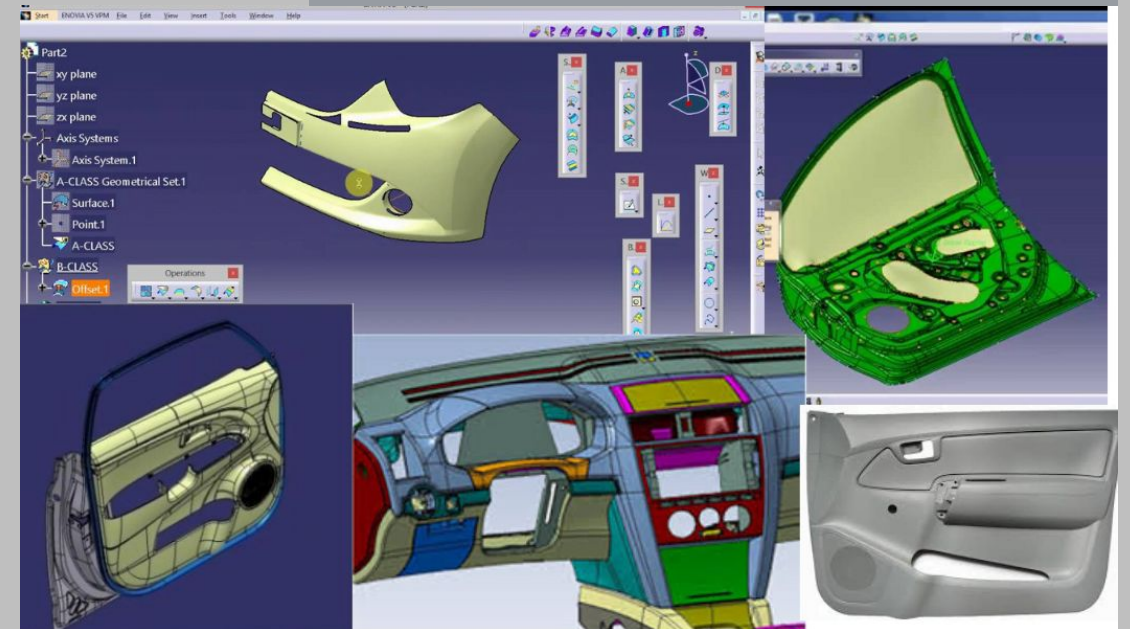

Design Quality

- Perceived Quality
 - Gap & Flush Technical Specs
 - Part Surface Quality
 - Pre-grain
 - Post-grain
 - Material Specification

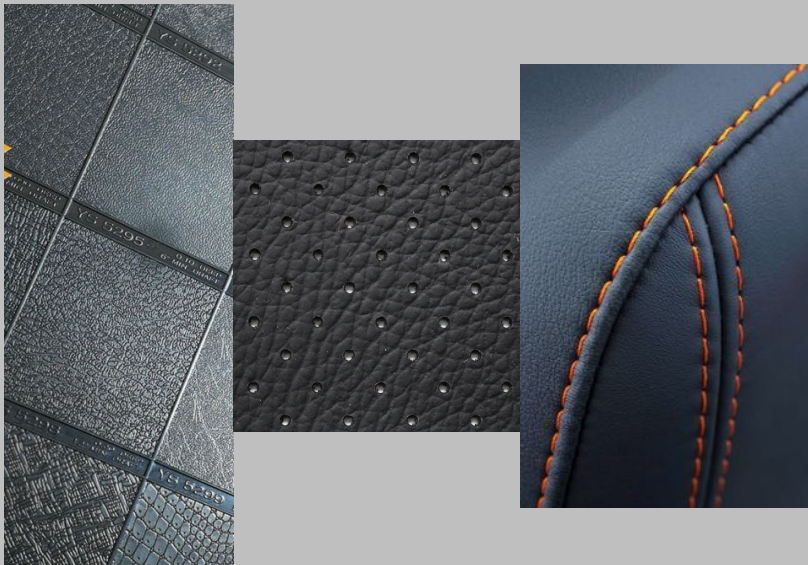
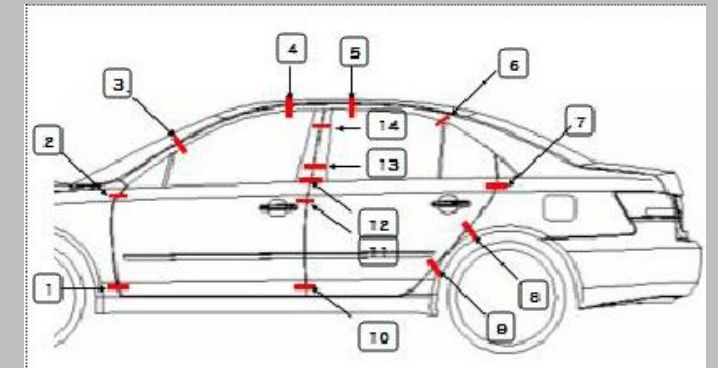
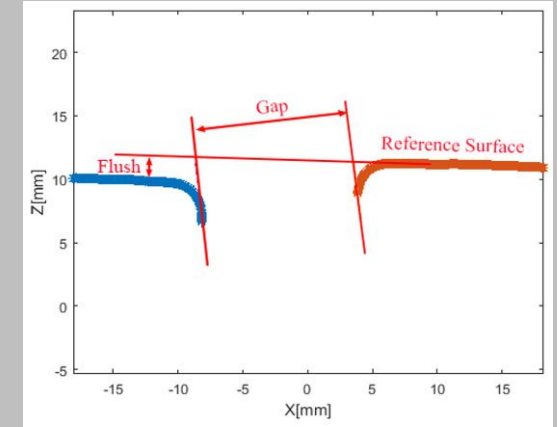

Getting Ahead & Leadership

- Personal Expectations
- Leading Small Teams
- Leading Entire Departments

Leadership is about making others better as a result of your presence and making sure that impact lasts in your absence

Personal Expectations

- Work Harder & Smarter
- Better Everyday
- Own it
- Prove it

Personal Expectations



Leading Small Teams

- Work Harder & Smarter
 - Better Everyday
 - Own it
 - Prove it
-
- Be the example
 - Always have their back
 - Be Present & Listen carefully
 - Encourage and be grateful

Personal Expectations



Leading Small Teams



Leading Entire Departments

- Work Harder & Smarter
 - Better Everyday
 - Own it
 - Prove it
-
- Be the example
 - Always have their back
 - Be Present & Listen carefully
 - Encourage and be grateful
-
- Be Present & Listen carefully
 - Ask, don't order
 - Guiding, not knowing
 - Be Humble

The Difference Between

**B
O
S
S**

Knows everything
Tells people
Criticizes
Talks fast and gives orders
Demands respect
Rules with threats not law
Depends on hearsay
Drives employees
Depends on authority
Inspires fear
Says "I"
Places blame for breakdowns
Knows how it's done
Uses People
Takes Credit
Commands
Says "Go"

Admits mistakes
Shows how to do things
Gives advice
Gives direction
Earns & deserves respect
Shows human kindness
Will investigate
Coaches employees
Depends on goodwill
Generates enthusiasm
Says "We"
Fixes the breakdown
Shows how it is done
Develops people
Gives credit
Asks
Says "Let's go"

**L
E
A
D
E
R**

The Difference Between

**B
O
S
S**

Knows everything
Tells people
Criticizes
Talks fast and gives orders
Demands respect
Rules with threats not law
Depends on hearsay
Drives employees
Depends on authority
Inspires fear
Says “I”
Places blame for breakdowns
Knows how it’s done
Uses People
Takes Credit
Commands
Says “Go”

Admits mistakes
Shows how to do things
Gives advice
Gives direction
Earns & deserves respect
Shows human kindness
Will investigate
Coaches employees
Depends on goodwill
Generates enthusiasm
Says “We”
Fixes the breakdown
Shows how it is done
Develops people
Gives credit
Asks
Says “Let’s go”

**L
E
A
D
E
R**



Thank

Feel free to reach out with any questions

Contact: James.JensenIII@hotmail.com

You